

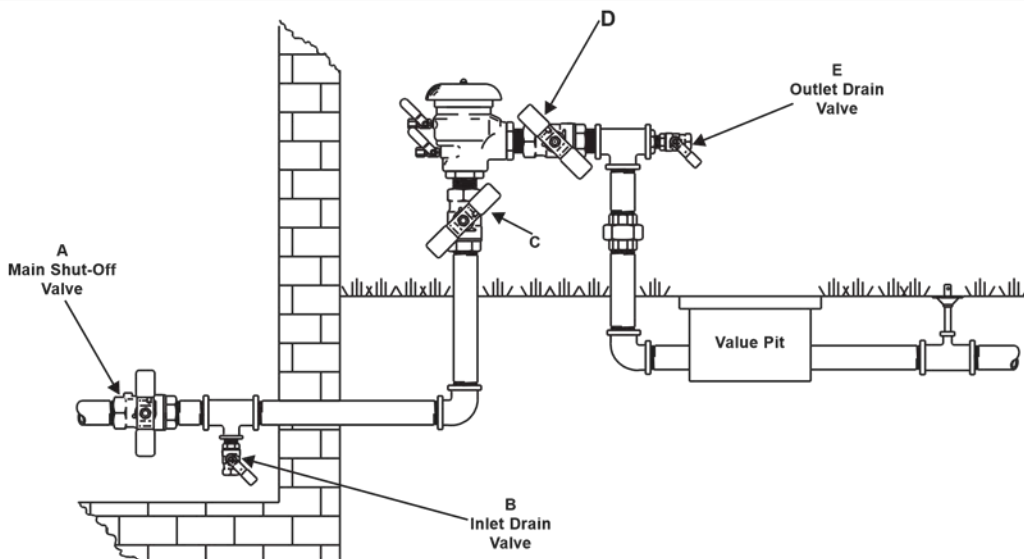

An SPX Process Equipment Operation

Pressure Vacuum Breaker Draining Procedure for Freeze Protection



SERVICE INSTRUCTIONS:

Backflow prevention assemblies must be drained for the winter in areas where freezing temperatures may occur. If water inside the assembly should freeze, damage to the assembly and the system may occur. Proper draining procedures, insulation from freezing using heat tape, and heated protective enclosures are all methods of freeze protection.

In order to drain an assembly to prevent freezing, several important points must be remembered:

1. The assembly can not be adequately drained through the testcocks. For proper draining follow the instructions detailed in the drain procedures section.
2. Drain valves must be added on the inlet side and outlet side of the assembly below the assembly (preferably below the freeze line if the remainder of the system is to be drained).
3. Compressed air of adequate volume may be used to "blowout" the system after the backflow preventer is drained.
4. After removing water from the system and assembly, the assembly shut-off valves, drain valves and testcocks should remain in a half open / half closed (45° degree) position to allow for full drainage of the ball valve shut-offs. If the assembly is installed with ball valve shut-offs, see draining procedure for ball valves on the reverse side of this sheet. The main shut-off to the system must remain closed during the winter period.

DRAINING PROCEDURE:

To drain the backflow prevention assembly for protection against freezing, use the following procedures:

1. Turn off the main shut-off valve (A) which provides water to the system.
2. Open all inlet and outlet drain valves on the system (B and E). Open inlet and outlet shut-off valves on backflow prevention assembly (C and D) and all testcocks. Leave in half open / half closed (45° degree) position to allow for full drainage of ball valve shut-offs. (See the ball valve freeze protection instructions for more details.)
3. Should you "blowout" the piping system down stream of the backflow prevention assembly, make sure the outlet drain valve (E) is open and the backflow prevention outlet shut-off valve (D) is closed.
4. Connect an air line to the outlet drain valve (E) and introduce air of adequate volume to clear downstream system of water.
5. **IMPORTANT:** Open outlet shut-off valves to the backflow preventer assembly (C and D) to a half open/half closed (45° degree) position after "blowout" procedure is complete.
6. Leave all drain valves (B and E), testcocks and ball or gate valves to backflow preventer (C and D) in a half open / half closed position for the winter to prevent freezing. **IMPORTANT:** When finished, make sure main shut-off valve (A) remains closed to prevent accidental refilling of the system.

BALL VALVES



An SPX Process Equipment Operation

Ball Valve Draining Procedure for Freeze Protection

Draining Procedure for Freeze Protection

Ball valves should be drained for the winter in areas where freezing temperatures may occur. Water will become trapped between the ball and valve body if the valve is left in either the full open or full closed position. If water should freeze between the ball and valve body, damage to the ball valve will occur.

After draining procedures on the backflow prevention assembly have been completed, all ball valves must be left in a half open / half closed (45° degree) position as shown in Figure A. Open the ball valve approximately 45° degrees while draining the pipeline and assembly to allow water between the ball and valve body to drain as shown in Figure B. Leave the ball valve in this position for the winter to prevent freeze damage.

The valve must be closed before the system can be repressurized.

NOTE: Open and close ball valves slowly at all times to prevent damage to the system.

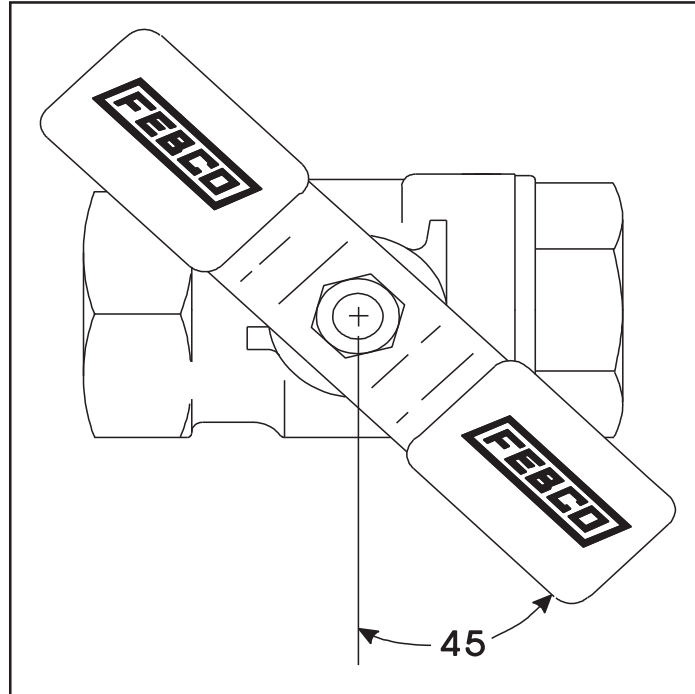

Figure A: Ball Valve in half open/half closed 45° degree position

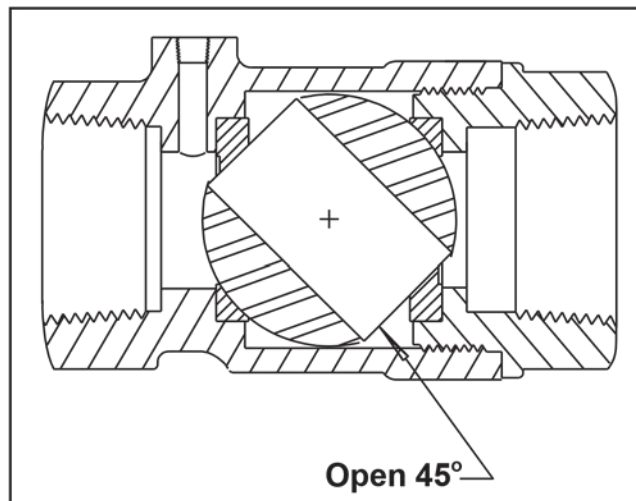

Figure B: Cutaway drawing displaying ball valve in half open/half closed position